

# 10 TON PACKAGE UNIT

## SPECIFICATIONS

Trane® Portable Packaged Air Conditioner units contain the best compressor technology available, in order to achieve the highest performance possible. Trane-built scroll compressors are designed specifically to ensure system quality.

These units have high efficiency condenser coils with increased capacity and energy efficiency. This assists with optimizing the required amount of power to operate.

U-shaped airflow allows for improved static capabilities.

The 10 ton package unit is mounted on a skid frame. These units can be stacked for transportation or can be placed on the ground or delivered on a temporary trailer.



**Call us today! (800)341-4297**



## GENERAL

◆ Trane® Package Unit Model	TSC120F3E
◆ CFM (Cubic Feet Per Minute)	4,000
◆ Air Supply	(1) 20" Plenums
◆ Air Return	(1) 20" Plenums
◆ Skid Mounted	-----
◆ Optional Trailer Mounted	-----

## DIMENSIONS

◆ Length	8'
◆ Width	5'
◆ Height	4' 11"
◆ Shipping Weight	3,000 LBS

## ELECTRICAL DATA

◆ Power Supply	208-230v/3p/60hz
◆ Connections	Series 16 Cam Type
◆ Minimum Circuit Ampacity	151.4 amps
◆ Min/Max Operational Volts	187/253 volts

## ADDITIONAL INFORMATION

- ◆ 72kw Heat Kit

## 10 TON PACKAGE FEATURES

- ◆ R-410A refrigerant
- ◆ Factory installed and commissioned ReliaTel™ controls
- ◆ Phase Monitor
- ◆ Trane 3-D™ Scroll compressors
- ◆ Two-inch standard efficiency filters
- ◆ Sloped condensate drain pan

# 10 TON PACKAGE UNIT

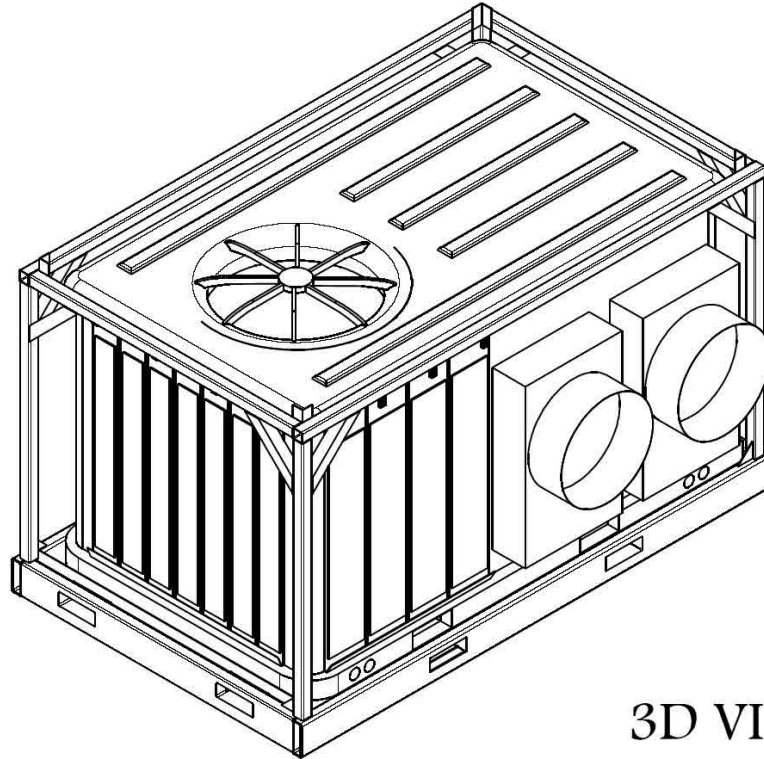

3D VIEW

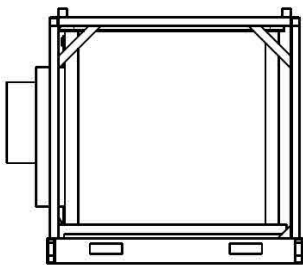

REAR VIEW

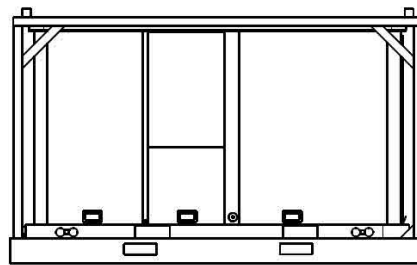

LEFT VIEW

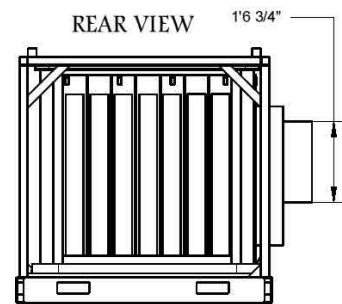

FRONT VIEW

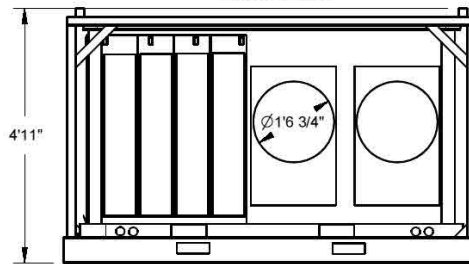

RIGHT VIEW

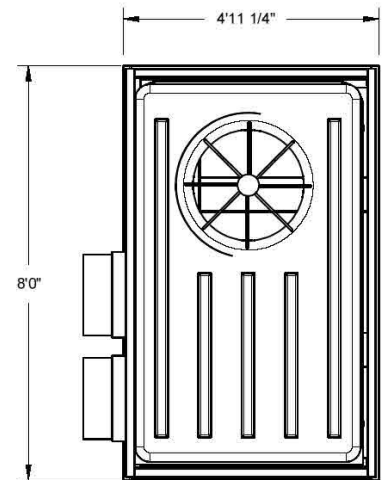

TOP VIEW